

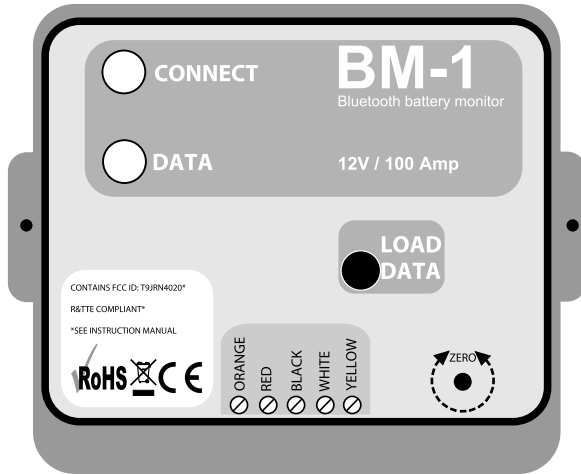

**DESIGNED AND  
MANUFACTURED  
IN ENGLAND**



# BM-1

## **Bluetooth Battery Monitor**



This device Contains Transmitter Module FCC ID: T9JRN4020

This device complies with Part 15 of the FCC Rules. Operation is subject to the following two conditions:

(1) this device may not cause harmful interference, and (2) this device must accept any interference received, including interference that may cause undesired operation

This equipment has been tested and found to comply with the limits for a Class B digital device, pursuant to part 15 of the FCC Rules. These limits are designed to provide reasonable protection against harmful interference in a residential installation. This equipment generates, uses and can radiate radio frequency energy, and if not installed and used in accordance with the instructions, may cause harmful interference to radio communications. However, there is no guarantee that interference will not occur in a particular installation. If this equipment does cause harmful interference to radio or television reception, which can be determined by turning the equipment off and on, the user is encouraged to try to correct the interference by one or more of the following measures:

Reorient or relocate the receiving antenna.

Increase the separation between the equipment and receiver.

Connect the equipment into an outlet on a circuit different from that to which the receiver is connected.

Consult the dealer or an experienced radio/TV technician for help.

The RN4020 module has been tested to R&TTE Directive 1999/5/EC Essential Requirements for Health and Safety (Article (3.1(a)), Electromagnetic Compatibility (EMC) (Article 3.1(b)), and Radio (Article 3.2) and are summarized in Table 3-1: European Compliance Testing.

A Notified Body Opinion has also been issued. All test reports are available on the RN4020 product web page at <http://www.microchip.com>.

## **INTRODUCTION**

The NASA BM1(BT) Bluetooth battery monitor is supplied complete with a 100 Amp 50mV shunt and all necessary cables to connect to the main service battery. It is intended to monitor a 12 volt lead-acid battery, or bank of batteries, with a total capacity between 5 and 600 Ampere-hours (Ahr). The current consumption of the device is typically 2 mA which represents a tiny discharge of less than 1.5 Ahr per month.

The unit monitors the main battery voltage, the current flowing into or out of the battery and calculates the best approximation of the state of charge and the time to charge or discharge. An alarm alerts the user if the charge gets dangerously low when load shedding or charging becomes necessary. A second input measures the voltage on the starter battery. As that battery is not normally under load its open circuit voltage gives a good indication of its condition.

The information is transmitted using Low Energy Bluetooth (Bluetooth 4) and can be viewed on any compatible device with a suitable App. An Android App can be freely downloaded from the Nasa Marine website while a third party more sophisticated Apple App, with additional features, can be found on the apple App store.

## **IMPORTANT SAFETY NOTICE**

Lead-acid batteries can emit hydrogen when in operation. Hydrogen and air forms a potentially explosive mixture. Accordingly, ensure that the area around the batteries is well-ventilated and extinguish all naked flames and prevent sparks.

Short-circuiting a battery with a metal tool or piece of jewellery can cause catastrophic currents to flow. Before undertaking any work on the electrical system remove all jewellery (such as rings or metal necklaces). Ensure that no metal tool can cause a short circuit. If you are not sufficiently skilled to undertake any part of this installation safely, you must seek the assistance of a suitably qualified person.

## **INSTALLATION OF THE BM1(BT) MONITOR**

- 1.** Connect the shunt cable to the monitor as shown on Figure 1. Be careful to connect the wires exactly as shown, noting that the black and white wires are joined at the shunt connection, and are connected separately at the monitor end of the cable.
  
- 2.** Mount the unit on a convenient bulkhead using the mounting flanges. Ensure the position you choose remains dry and free from contaminants at all times. It is good practice to run the cables vertically downwards from the unit, even if they later have to rise to connect to the battery. Doing so prevents any water that might get onto the cables from running back along the cables and into the unit.
  
- 3.** Ensure that all loads are switched off
  
- 4.** Disconnect all the wires from the negative terminal of the battery and connect to the shunt as shown on Figure 1. Ensure the shunt is positioned where it cannot come into electrical contact with other parts and ensure it will remain dry and free from contaminants. Also note that the shunt can get warm when heavy currents flow, so ensure it is secured in a position where its heat cannot affect other parts. Take care not to over tighten the connections to the shunt.
  
- 5.** Connect the Black and White wires and Yellow wire to the shunt as shown on Figure 1.

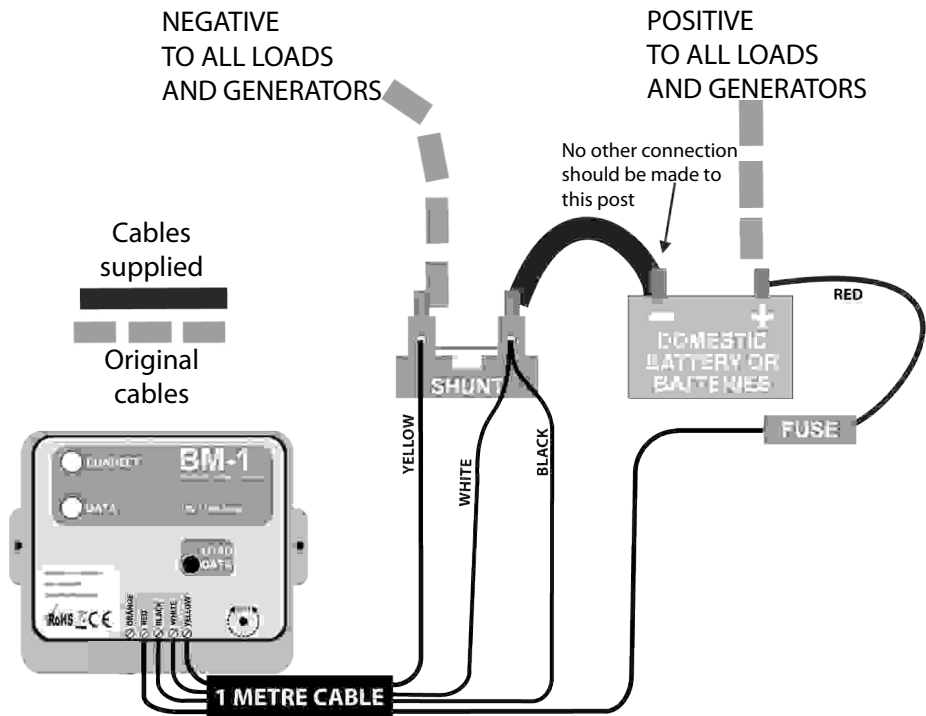

Figure 1 - Domestic battery only

6. Connect the short link cable to the shunt and then to the negative terminal of the battery. This should be the only connection to the negative battery terminal.

7. If the starter battery voltage is to be monitored then connect the orange wire (not supplied) to the positive terminal of the starter battery as shown in Figure 2. A 1 amp fuse close to the starter battery will afford protection if a fault occurs.



## INITIALISING AND USING THE BM1(BT) MONITOR

The bluetooth transmitter will now be advertising its presence so select the Android app on your phone or tablet and press the "scan for device" icon. After a few seconds the scan will stop and all low energy bluetooth devices in range will be listed. The default name for the battery monitor is "BoatName".

Click on the "BoatName" icon to connect with the monitor and display the main battery's rated capacity, the voltage, the current flowing into the load, the state of charge and the time to go. The green "CONNECT" led on the monitor will illuminate to indicate that connection has been established. Pressing the "starter battery" icon will display the starter battery voltage for a few seconds before returning to the service battery characteristics. Press the "settings" icon to edit the stored information. First select "Amp hour capacity" and enter the total capacity of your service battery.

(Example: If you have two 110 Ahr batteries wired in parallel then you would enter 220 Ahr.) The entered capacity must be in the range 5 to 600 Ahr. Now click on "BoatName" and enter the name you want as your device name. This must be 8 characters long. (Upper and lower case letters, numbers and spaces can be used). Then select the typical temperature of the battery.

Finally, when you press the "submit" key the data is made available to the BM1(BT) monitor. However the monitor will not accept the new data without confirmation. The red LED on the monitor will flash for 15 seconds. To accept the data you must press the "LOAD DATA" key on the monitor while the LED is flashing. (This process ensures that a third party cannot alter data in your battery monitor.)

After accepting new data the bluetooth connection will be terminated. Now, close the app and wait one minute, when you next open the app it will open with the new name and the parameters you have selected. The monitor is intended to be permanently connected to the battery but, if you should need to turn it off for any reason, then, when re-starting, it is important that the monitor sees a load of a few amps until the state of charge settles before putting the battery on charge.

The zero current has been set in the factory and should not require subsequent adjustment. However if a small residual current is detected which cannot be attributed to a clock, sensor or standby LED etc. the zero set can be adjusted. Turn slightly clockwise for a small residual discharge current or anti-clockwise for a residual charge current. The control has a limited range of just a few hundred mA.

## **BATTERY MANAGEMENT BASICS**

After Voltage and Current, the most useful measurement available from a battery condition monitor is the state of charge of the battery. However, estimation of the state of charge of lead-acid batteries is never exact. The problem of making accurate estimates results from the characteristics of the cells, the electrolyte, and the history of currents drawn from (discharge) and supplied to (charge) the battery. The basis for the best capacity estimates is that the starting condition is known. The only well-established "known" state of a battery is when it is fully charged after a long period of trickle or float charging, usually on a shore or regulated alternator-driven charging system. Discharging a fully charged new battery at a current  $1/20$  of the manufacturer's stated capacity will discharge it fully in 20 hours. This current is known as the "20-hour rate".

So, for example, if a battery has a stated capacity of 100 Ahr, then the 20-hour rate for that battery is 5 Amps (because  $100/20 = 5$ ). Likewise, a 40 Ahr battery would have a 20-hour rate of 2 Amps (because  $40/20 = 2$ ). If higher currents than the 20-hour rate are drawn from the battery, the available capacity is reduced. For example, if it is steadily discharged at 10 times the 20-hour rate (50 Amps from a 100 Ahr battery), the available capacity falls to about half of the stated capacity. The battery will be flat after about 1 hour instead of the expected 2 hours. (However, if the battery is left to recover with the heavy load removed, most of its remaining capacity will return after perhaps 20 hours' resting or at a discharge rate close to the 20-hour rate.) The BM1 makes due allowance for these effects when estimating the battery's state of charge and the expected time to discharge the battery fully.



When the battery is being charged, the voltage is no longer a reliable estimate of the state of charge, and so the BM1 integrates the Ampere hours added to the last known capacity to estimate the battery's state of charge on a continuous basis. Allowance for charge efficiency (not all charging current results in useful charge in the battery) is also computed. Available battery capacity is significantly reduced at temperatures significantly below 20C. The value quoted by the manufacturers is valid at 20C. However, at 0C the capacity may be only 90%, and at -20C may be only 70% of the 20C value. A small increase in capacity is achieved at battery temperatures above 20C, rising to about 105% of the nominal value at 40C. The effects of cell deterioration on the available capacity are significant. If the battery is charged for long periods, gassing takes place. The gases are Hydrogen and Oxygen, derived from the water in the battery acid. Loss of this water needs to be made up by topping up the cells if possible, or by avoiding lengthy overcharges in sealed cells. Other irretrievable effects include sulphation (encouraged by leaving the battery flat for long periods), and deterioration of the cells' plates. If the battery voltage falls below 10.7 Volts (for a nominally 12 Volt battery), and charging is not started, sulphation of the plates can begin.

The BM1 has an alarm when the voltage falls below 10.7 Volts. If the alarm is triggered, it is important to reduce the current being drawn immediately, and if possible place the battery on charge, to avoid permanent damage to the cells. If the alarm is ignored, the total number of charge/discharge cycles which the battery will survive before it loses a substantial fraction of its nominal capacity may be substantially reduced.

All of these (and other effects) reduce the available charge after fully charging the battery. If the effects are ignored, the BM1 will incorrectly estimate that more capacity is available at any state of discharge than is actually the case. If so, it is wise to alter the nominal capacity stored in the unit to match the reality of the battery's condition.

**Q Why is the red LED not flashing?**

A Check that the wiring is correct. Check the fuse. Check that there is 12 volt at the red and black terminals of the monitor.

**Q The discharge current reads correctly but the charge current reads low or zero.**

A You have probably still got a heavy cable between the engine block and the battery negative terminal so the charge current is bypassing the shunt. Refer to the wiring diagram.

**Q Why does my BM1 show that the number of hours remaining is high or low when a constant discharge current is flowing?.**

A The actual battery capacity is different from the value you have entered in Engineering. Adjust the battery capacity in Engineering to match the battery.

**Q My battery is made up of a bank of several batteries. Is that a problem?**

A Not as long as the combination produces a nominal 12 volts, and all the current drawn from the bank passes through the shunt.

**Q Can the BM1 monitor my engine starting battery as well as my service battery?**

A Yes it can monitor the engine start battery voltage. The open current voltage of the starter battery can be used to estimate its state of charge

**Q I have another voltmeter on my boat which shows a different value to the BM1 indication.**

A The BM1 very accurately measures the voltage directly across the battery terminals. Other voltmeters may read differently owing to volt drops in the boat's wiring.

A

**Q Why does my BM1 show a higher capacity immediately after charging than it does after a few minutes' discharging?**

A This is an unavoidable feature of battery chemistry, which varies from battery to battery, and the charging regime used.

**Q Do I need to disconnect my BM1 when I leave the boat for long periods?**

A No. The BM1 is designed to be permanently connected to the battery. It is independently fused, and draws only 2 mA from the battery. At such a low current, it would take several years to discharge a typical fully-charged marine service battery.

**Q Why does my battery seem to have less capacity than it says on its label?**

A The value on the manufacturer's label is seldom the value achieved in service, because of the deterioration of the cells' plates and many other factors. If it seems to have much lower than its expected capacity, it may need replacement, or you may feel that changing the nominal capacity from the Engineering mode will suffice to let you know well enough the percentage charge remaining.

**Q Why does my BM1 show a large net charge after a day's cruising?**

A You have put more charge into the battery than you have used. The amount should not exceed the total battery capacity. If it does, it may be wise to check that the charging system is working correctly and is not over-charging the battery.

**Q When on heavy load, the time to run is lower than I expect. Is this correct?**

A YES. When heavily loaded, a lead-acid battery delivers less energy than expected owing to electrolyte exhaustion and stagnation. When the battery is delivering heavy currents the BM1(BT) uses Peukert's equation to allow for these effects and so show a better estimate for the time to run.

**Q if a power transient crashes the monitor, can I reset it?**

A This is very unlikely to occur but a reset can be performed by removing the fuse for about ten seconds then replacing it.

# IMPORTANT READ THIS BEFORE UNPACKING INSTRUMENT

Prior to unpacking this instrument read and fully understand the installation instructions. Only proceed with the installation if you are competent to do so. Nasa Marine Ltd. will not accept any responsibility for injury or damage caused by, during or as a result of the installation of this product. Any piece of equipment can fail due to a number of causes. Do not install this equipment if it is the only source of information and its failure could result in injury or death. Instead return the instrument to your retailer for full credit. Remember this equipment is an aid to navigation and not a substitute for proper seamanship. This instrument is used at your own risk, use it prudently and check its operation from time to time against other data. Inspect the installation from time to time and seek advice if any part thereof is not fully seaworthy.

## LIMITED WARRANTY

Nasa Marine Ltd. warrants this instrument to be substantially free of defects in both materials and workmanship for a period of one year from the date of purchase. Nasa Marine Ltd. will at its discretion repair or replace any components which fail in normal use within the warranty period. Such repairs or replacements will be made at no charge to the customer for parts and labour. The customer is however responsible for transport costs. This warranty excludes failures resulting from abuse, misuse, accident or unauthorised modifications or repairs. In no event shall Nasa Marine Ltd. be liable for incidental, special, indirect or consequential damages, whether resulting from the use, misuse, the inability to correctly use the instrument or from defects in the instrument. If any of the above terms are unacceptable to you then return the instrument unopened and unused to your retailer for full credit.

Name \_\_\_\_\_

Address \_\_\_\_\_

Dealer Name \_\_\_\_\_

Address \_\_\_\_\_

Date of Purchase \_\_\_\_\_

**Proof of purchase may be required for warranty claims.**

**Nasa Marine Ltd.  
Boulton Road, Stevenage, Herts SG1 4QG England**

### Declaration of Conformity

NASA Marine Ltd declare this product is in compliance with the essential requirements of R&TTE directive 1995/5/EC.

The original Declaration of Conformity certificate can be requested at [info@nasamarine.com](mailto:info@nasamarine.com)

**THIS PRODUCT IS INTENDED FOR USE ONLY ON NON SOLAS VESSELS**

